



ES9102A

SABRE³² Reference 32-bit Stereo ADC
Product Brief

Device	Description	DNR (dB-A)	THD+N (dB)	32-bit Digital Filter	8-band Biquad Filter	I2S/SPDIF Output	Sample Rate
ES9102A	SABRE³² Reference 32-bit Audio ADC	127 (Mono) 124 (Stereo)	-120 (Mono) -118 (Stereo)	Programmable	Programmable	Yes	Up to 384kHz

The **SABRE³² Reference ADC** is a two-channel 32-bit analog-to-digital (A/D) converter targeted for consumer applications such as audio pre-amplifier, audio processor, A/V receiver and professional audio applications such as recording systems, mixer consoles and digital audio workstations.

Using the ESS proprietary 32-bit Hyperstream™ ADC architecture, the **SABRE³² Reference ADC** delivers an unprecedented DNR of 127dB and THD+N of -120dB in mono mode (or DNR of 124dB and THD+N of -118dB in stereo mode), a performance level that will satisfy the most demanding audio enthusiasts.

For highest performance, the **SABRE³² Reference ADC** implements a 32-bit programmable decimation filter and outputs the full 32-bit resolution in I2S mode, or 24-bit resolution in SPDIF mode. A digital high-pass filter is available for DC removal. Additionally, a programmable 8-band biquad filter is implemented for RIAA or custom equalization. The **SABRE³² Reference ADC** supports synchronous SPDIF or I2S master/slave output, or asynchronous I2S slave output relative to the master clock for up to 384kHz sample rate and consumes less than 200mW.

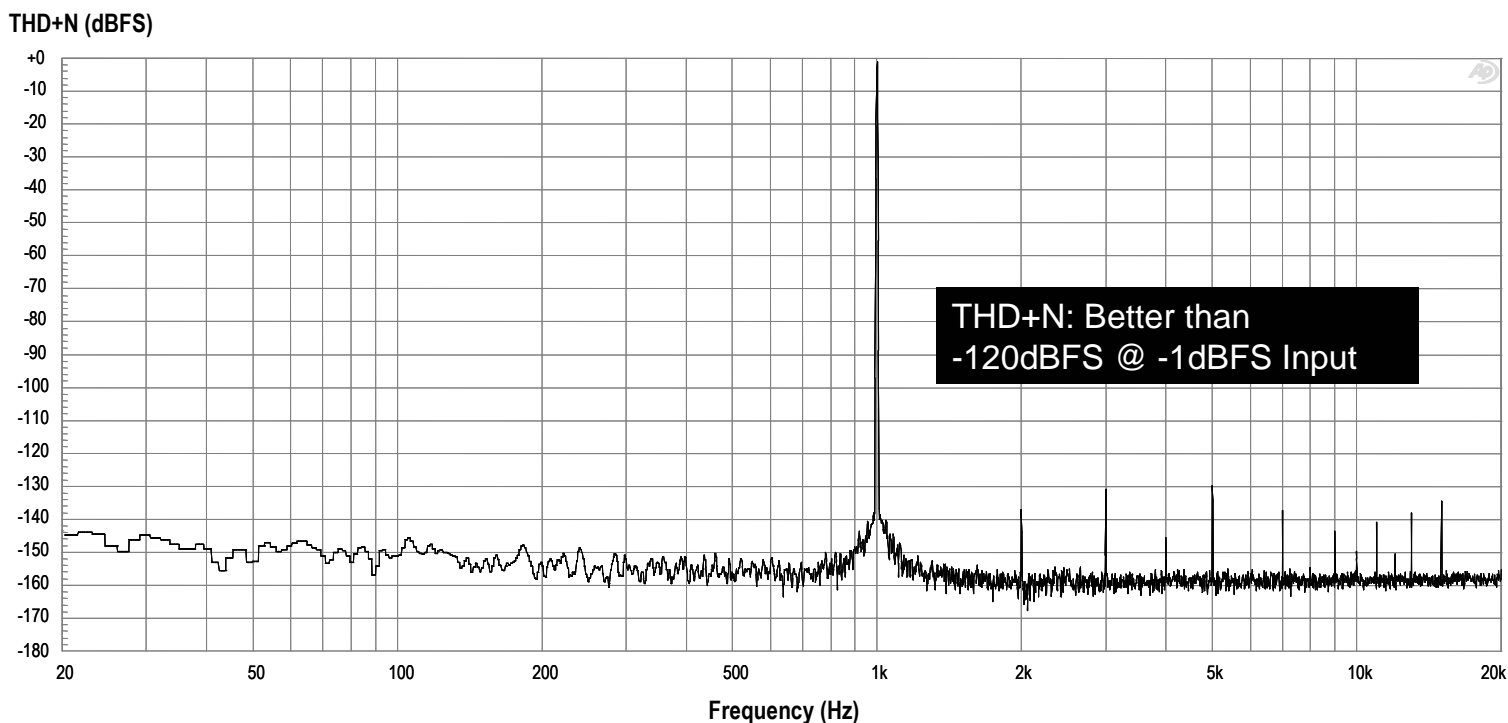
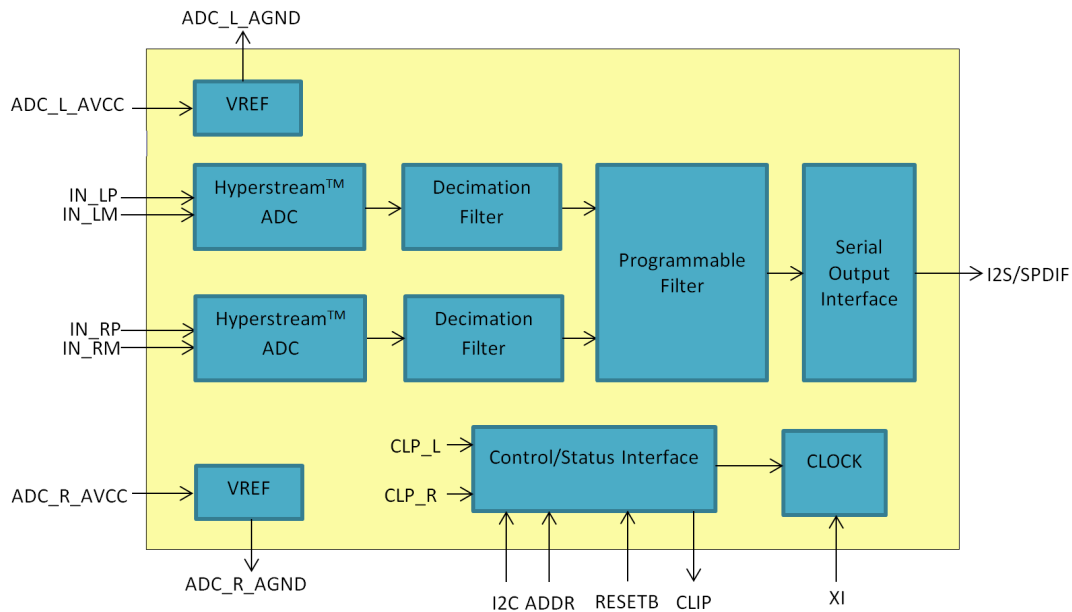

Figure 1: ES9102A THD+N versus frequency

ES9102A Product Brief



FUNCTIONAL BLOCK DIAGRAM



FEATURE	BENEFIT
32-bit Hyperstream™ ADC architecture <ul style="list-style-type: none"> ○ 127dB dynamic range (mono mode) ○ -120dB THD+N (mono mode) 	Unprecedented dynamic range and ultra low distortion
32-bit Programmable decimation (FIR) filter <ul style="list-style-type: none"> ○ Built-in sharp or low-group delay filters, or ○ User customizable characteristics 	Customizable FIR decimation filters for any application
Programmable 8-band biquad filter <ul style="list-style-type: none"> ○ Built-in RIAA filter ○ User customizable characteristics 	Customizable equalization for any application
Programmable Digital High-pass filter	Eliminates input DC offset
Up to 384kHz sampling rate	Compatible with DVD-audio and professional applications
I2C, SPI or hardware based control	Configured by microcontroller or used standalone
Flexible digital output modes	Synchronous SPDIF or I2S master/slave output, or asynchronous I2S slave output relative to master clock
Low power in a small package <ul style="list-style-type: none"> ○ <200mW power consumption ○ 48-LQFP package 	Simplifies PCB layout and power supply design

APPLICATIONS

- Professional recording systems
- Studio mixing console
- Digital audio workstations
- Audio/Video receivers
- Audio preamplifiers
- Audio processor